



FL1000V2-WALL MOUNT

FL1000V2 FILTRATION UNIT

Wall/Equipment Mount Kidney Loop Filtration Unit.

Ideal for small gear-box and small hydraulic reservoirs.



INCLUDES

- 1 FL1000V2 Filtration Unit
- 1 Spin-On Filter
- 1 Threaded Filter Adapter
- 1 Wall-Equipment Mount Bracket,
- 1 Hose/fittings Start-Up Kit,
- 1 24v Power Supply

SPECIFICATIONS



Flow Rates *

- 0.03-0.67 gal/min (1.8-40 gph)

*Actual flow rates depend on filter selection, psi, viscosity and temperature of the oil
(Flow rates for Depth filters will be on the lower end of the range)

Measured at 40° C, 50% approximate pump speed

Gear Oil Specs

- Typically up to ISO 220 **
- Synthetic Oil recommend for Heavier oils
- Service Sump Size typically 0-10 Gals

Oils that have a viscosity grade of **ISO 150 or higher are recommended to have a **Viscosity Index (VI) of 125 or greater**

Hydraulic oil Specs

- Typically AW 32, 46, 68, 100, 150
- Service Reservoir Typically Up to 100 Gals depending on flow rate

Pump/Motor

- Magnet Drive Gear Pump
- 24 VDC Supply Voltage
- Brushless Motor Assy
- Rated 3A, 50 Watt
- Speed Range from 150 to 3650 rpm

Operating Conditions

- Storage Temperate Range -40° to 70° C
- Operating Ambient Temperature Range 0°-70° C (32°-158° F)
- Max Fluid Temperature 120° C
- IP Rating: IP55
- Relative Humidity 8 to 90% (non condensing)
- Thermal motor protection shutdown temp 90° +/- 4° C (194° F)

Power

- Power Supply Standard 120v wall power with 24v adapter
- Amp draw 1.9-2.9, max 3-3.4 amps

Dimensions (with Standard Pump, without filter)

Wall/Equipment Mounted	With Hand Carry Stand
W 8.38"	W 8.38"
H 5.00"	H 17.97"
D 6.25"	D 14"

Weight (with Standard Pump, without Filter and fluid)

Wall/Equipment Mounted	With Hand Carry Stand
8.8 lbs.	13.8 lbs.

Dimensions–Wall Mount

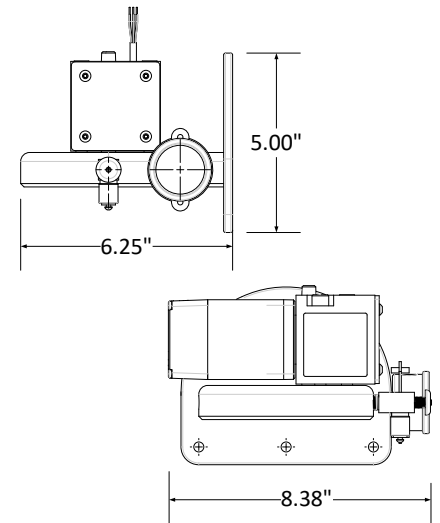

Dimensions–Hand-Carry Stand

